

1 INTRODUCTION

This packing list gives step-by-step procedures for calibrating the Model 3321/3322/3330 LCZ Meter using the supplied calibration program. This calibration procedure can be performed at specified intervals, or if the performance verification procedures covered in Section 1 of the Model 3321/3322 Service Manual or Model 3330 Service Manual show that instrument performance is not within specifications.

During calibration, a set of standard resistances is measured twice, the resulting data is processed by the computer, and the resulting calibration constants are downloaded into the LCZ meter. For the Model 3330, additional measurements are made using a digital multimeter in order to calibrate the voltage measurement display function and signal level.

NOTE

If the calibration procedures cannot be performed successfully, refer to the repair information in the service manual unless the unit is still under warranty. (Units still under warranty should be returned to the factory or authorized repair facility for repair.)

2 CALIBRATION PROGRAM REQUIREMENTS

The supplied calibration program must be used to calibrate the Model 3321/3322/3330. This program is intended to run on an IBM PC AT or compatible computer with appropriate hardware, as covered below.

2.1 Computer hardware requirements

The following computer hardware is required for calibration:

- IBM-PC AT, or compatible computer.
- One of the two following IEEE-488 interfaces for the computer:
 - National Instruments PC-IIA interface card.
 - Keithley Metrabyte KM-488-ROM interface card.

2.1.1 Using the National Instruments PC-IIA board

Use the factory default settings with the National Instruments PC-IIA interface board. When using older versions of the PC-IIA interface (those not equipped with a VLSI chip), the interface driver software must be configured for use with the PC-IIA card. The older version of the interface software uses a single driver for both the PC-II and PC-IIA boards, and the driver defaults to the PC-II board. Use the "IBCONF.EXE" utility supplied with the interface to change the driver configuration for operation with the PC-IIA board. See the interface board documentation for details.

2.1.2 Using the Keithley Metrabyte KM-488-ROM board

When using the KM-488-ROM board, use the default switch settings for all operating modes except for the ROM, which should be disabled. Refer to the documentation supplied with the interface board for detailed information on defaults and disabling the on-card ROM.

2.2 Computer software requirements

The following computer software is required to run the calibration programs:

- MS-DOS or PC-DOS, version 3.30 or later.

2.3 Program installation

Before using the supplied calibration program, first make a backup copy of the diskette, then copy the contents of the diskette to a convenient subdirectory on your hard drive. Be sure to select this subdirectory as the current directory before attempting to run the calibration program.

The following programs are supplied on the distribution diskette or created during program execution:

- CAL.EXE: Calibration program intended for use in calibrating the Model 3321/3322/3330.
- MAKEFILE.EXE: A utility program that allows you to set up the "REFDATA" file values for your particular set of resistance standards to ensure accurate calibration.
- SAVESET: A file that contains the environment data variables for the calibration program. Note that this file must be located in the same directory as the calibration program, and the filename cannot be changed.
- REFDATA: The reference data file that contains the actual resistance, capacitance, and inductance values of the resistance standards used by the calibration program. Note that this file must be located in a path specified by the calibration program environment data variables, which are specified when the program is run.

3 RECOMMENDED CALIBRATION EQUIPMENT

Table 1 summarizes recommended equipment for calibrating the Model 3321/3322/3330. This list does not include computer hardware, which is covered separately in paragraph 2.

Table 1. Recommended test equipment for calibration

Equipment	Manufacturer	Description
Resistance standards*	Hewlett-Packard HP 16074A	OPEN, SHORT, 100Ω, 1kΩ, 10kΩ, 100kΩ values
Digital Multimeter**	Hewlett-Packard 3458A or Fluke 8840A/8842A	System multimeter
GPIB cable(s)***	Keithley 7007-1	Shielded IEEE-488 cable
BNC cable**	Keithley 7051	BNC-to-BNC cable
BNC Adapter**		BNC-to-dual banana plug
Shorting jumper		Test lead with clips on each end

- * Resistance standards should be accurately characterized for resistance, series inductance, and parallel capacitance. See the supplied calibration data for values.
- ** Required only when calibrating Model 3330. Multimeter must be equipped with IEEE-488 interface.
- *** One GPIB cable required for Model 3321/3322 calibration. Two GPIB cables required for Model 3330 calibration.

4 CALIBRATION ENVIRONMENT

Calibration should be performed under the following conditions:

Temperature: 23°C ± 1°C

Humidity: 50% ± 20%

Supply voltage: 120VAC or 220VAC ±5%

The Model 3321/3322/3330 should be turned on and allowed to warm up for one-half hour before calibration. If the instrument has been subjected to extreme temperature or humidity, allow additional time for stabilization.

5 REFERENCE DATA FILE

5.1 Overview

The reference data file, "REFDATA," stores the actual resistance, series inductance, and parallel capacitance of the resistance standards you use for calibrating the LCZ meter. Data stored in this file are automatically read by the calibration program at run time.

Before performing calibration, you should update the reference data file with the actual values of the resistance standards you intend to use. In addition, these values should be updated whenever the resistance standards are calibrated.

There are two general ways to create the reference data file:

1. Use a text editor to edit the current file.
2. Use the supplied utility called "MAKEFILE.EXE" to create the reference data file.

Each of these methods is outlined below.

5.2 Resistance standards values

Resistance standards values are supplied by the manufacturer on a calibration sheet. In addition to the resistance value, both an inductance and capacitance value will be supplied. If the standard is capacitive, the inductance will be specified as a negative value. Similarly, the capacitance will be specified as a negative value if the standard is inductive. Any negative capacitance or inductance value should be entered as 0 in the reference data file, as outlined below.

5.3 Editing the reference data file

Use an ASCII text editor to edit the present "REFDATA" file. An example of the file is shown below:

#Reference Z	R-standards	123456
#Date: 10-18-1992 15:20:57		
# 100 Ω		
100	0	0
# 1k Ω		
1000	0	0
# 10k Ω		
10000	0	0
#100k Ω		
100E3	0	0

Note that the file includes the serial number, date, and time created. The four lines of calibration data information are for the four standards in the following order: 100 Ω , 1k Ω , 10k Ω , and 100k Ω . Note that no values for the OPEN and SHORT standards are included in the file.

Values may be entered in standard floating point format with scientific notation as necessary. Any line that begins with the # character is assumed to be a comment line and is not interpreted as a standard value by the calibration program.

NOTE

Be sure to maintain the proper file format outlined above, or the calibration program will not run properly.

Each calibration data line has three numeric values, which are delimited by space or tab characters. The first value is the resistance in ohms (Ω), the second value is the parallel capacitance in farads (F), and the third value is the inductance in henries (H). If a capacitance or inductance value is listed as being negative, enter a value of 0 for that parameter in the reference data file.

5.4 Using the MAKEFILE.EXE utility

The preferred method to create the reference data file is to use the "MAKEFILE.EXE" utility. Follow the steps below to use this utility to create the reference data file.

1. While in the calibration program subdirectory, type in the following:

MAKEFILE <Enter>

The program will prompt you to enter the 100 Ω resistance standard values as follows:

```
INPUT STANDARD DATA.  
  
STANDARD:    100  $\Omega$   
  
Rdc =
```

2. Enter the actual resistance value of your 100 Ω resistance standard in ohms, then press <Enter>.
3. The computer will then prompt you to enter the parallel capacitance of your standard at the following prompt:

Cp =

4. If the capacitance is listed as a positive value, enter the capacitance value in farads, then press <Enter>. If the capacitance is listed as a negative value, enter a value of 0 for Cp.
5. The computer will then prompt you to enter the series inductance of the 100 Ω standard:

Ls =

6. If the inductance listed on the calibration sheet is positive, enter the series inductance in henries, then press <Enter>. If the listed inductance is negative, enter a value of 0 for Ls.
7. Repeat steps 1 through 6 for the 1k Ω , 10k Ω , and 100k Ω resistance standards.
8. After you have entered all resistance standards values, the computer will display a summary of all values:

```
CALIBRATION STANDARD DATA  
  
STANDARD:  100 $\Omega$     Rdc: 100    Cp: 0    Ls: 0  
STANDARD:  1k $\Omega$     Rdc: 1000   Cp: 0    Ls: 0  
STANDARD:  10k $\Omega$    Rdc: 10000  Cp: 0    Ls: 0  
STANDARD:  100k $\Omega$   Rdc: 100E3  Cp: 0    Ls: 0  
  
If OK, press [RETURN key].
```

9. Press <Enter> if all values are correct, or press any other key to re-enter standards values. Follow steps 1 through 6 above to re-enter values.
10. After all values are entered and accepted, the program will prompt you for the reference data filename:

STANDARD FILE NAME

File name 'refdata'.

[RETURN] key to continue. Any other key to change filename

11. Simply press <Enter> to use the default "REFDATA" filename, or press any other key, then enter the desired filename at the prompt. NOTE: If you use a filename other than "REFDATA," you must also change the corresponding environment data variable in the calibration program. See paragraph 6 for details.
12. Finally, enter the serial number of your standards set at the prompt, then press <Enter>. The reference data file will then be saved using the selected filename, and the program will end.

6 CALIBRATION PROCEDURE

The following paragraphs will take you through the procedure necessary to complete calibration of the Model 3321/3322/3330 LCZ Meter. Before performing calibration, you must have previously completed the following:

- Installed the calibration software (paragraph 2).
- Installed and configured the computer IEEE-488 interface.
- Setup the reference data file with the correct resistance standards values (paragraph 5).

6.1 Hardware preparation

6.1.1 Connections

Before performing calibration, the Model 3321/3322/3330 must be connected to the GPIB (IEEE-488) interface of the computer. Use only a shielded IEEE-488 cable such as the recommended Keithley Model 7007-1.

NOTE

If you are calibrating multiple units, connect only one Model 3321/3322/3330 to the IEEE-488 bus at a time. Manually change bus connections when calibrating more than one LCZ meter during a calibration session.

If you are calibrating the Model 3330, connect the multimeter to the computer and the LCZ meter, as shown in Figure 1.

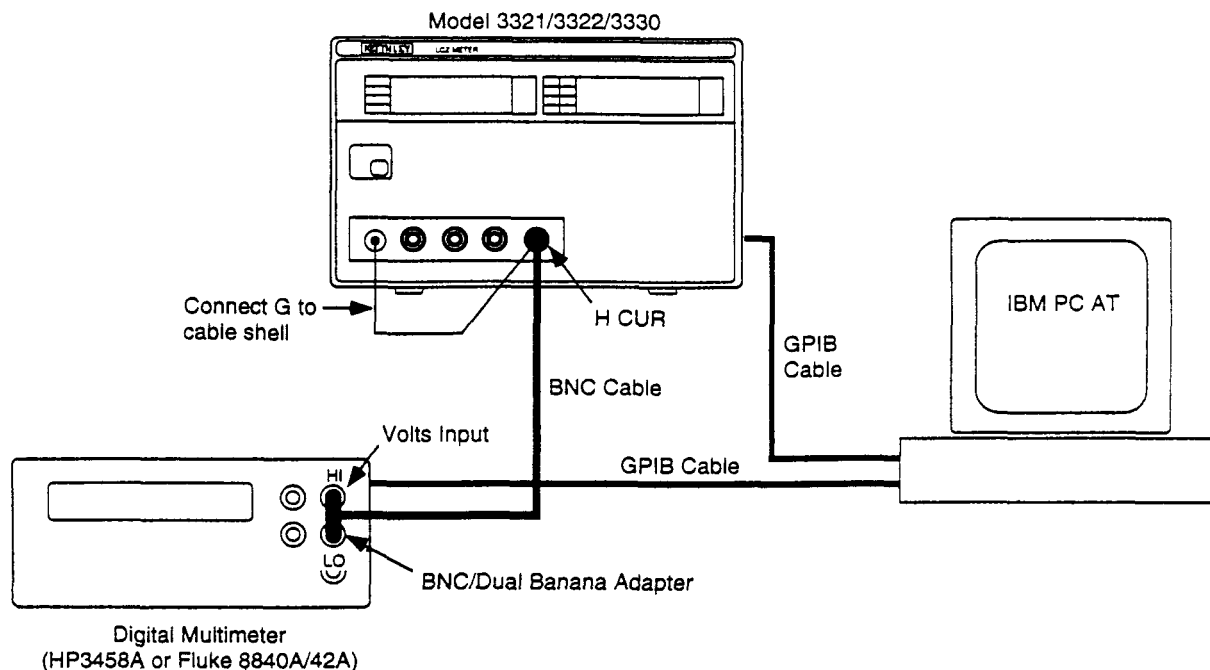

Note : Multimeter is required only when calibrating Model 3330 LCZ Meter. Connect multimeter as shown only when calibrating voltage display and signal level (see text).

Figure 1. Calibration connections

6.1.2 Power-up procedure

1. Turn on the LCZ meter. The instrument will begin its self-calibration cycle.
2. The **A** DISPLAY will show "CAL," while the **B** DISPLAY will count down to 0.
3. If "EEEEEE" and "22222" are displayed on the **A** DISPLAY and **B** DISPLAY, a calibration constants error has been detected, and calibration cannot be performed without clearing the error. Use the following procedure to clear the error before performing calibration:
 - A. Leave the instrument turned on with the "EEEEEE" and "22222" messages still displayed on the **A** DISPLAY and the **B** DISPLAY.
 - B. Remove the rubber plug that covers the access hole on the rear panel of the LCZ meter.
 - C. Connect one end of the Adjust terminal shorting probe to the front panel G terminal, as shown in Figure 2.
 - D. Momentarily touch the other end of the probe to TP101 through the rear panel access hole, and verify that the "EEEEEE 22222" error message has been cleared. The instrument will then enter the normal measurement mode.
4. After turning on the power, allow a 30-minute warm-up period before beginning the calibration procedure.

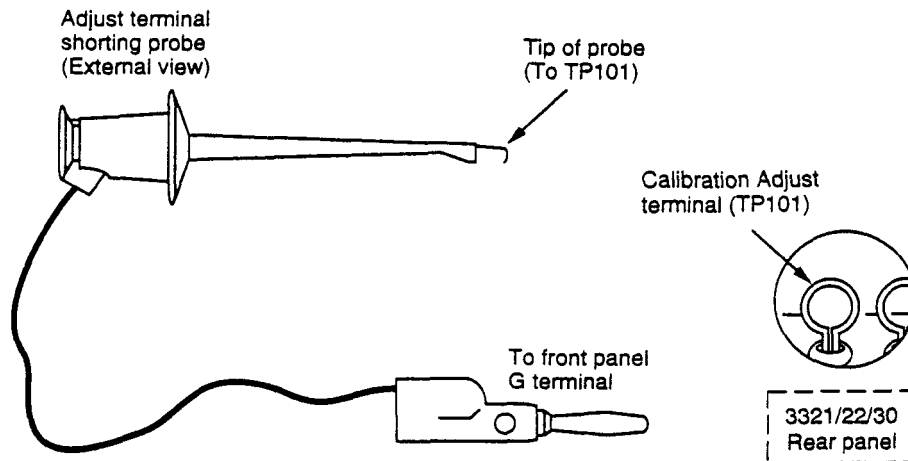

Figure 2. Shorting the calibration adjust terminal

6.1.3 GPIB primary addresses

The GPIB primary address must be the same as that specified in the calibration program (2). Similarly, the GPIB delimiter should be set to <CR> <LF>. These parameters are set as a single number, with the integer part of the number representing the primary address (0-30), and the fractional part of the number determining the delimiter (0 = <CR> <LF>, 1 = <CR> only). For example, the factory default is 2.0, which defines a primary address of 2 and a <CR> <LF> delimiter sequence. The address/delimiter must be set to 2.0 when using the calibration program.

Setting the Model 3321 address and delimiter

1. Press the AUTO/GPIB key for at least three seconds.
2. Verify that the desired address and delimiter settings are shown on the **B** DISPLAY section.
3. If the address/delimiter parameter is not set to 2.0, use the |Z| - 0, ESR, and G keys to set the address/delimiter parameter to 2.0.
4. Press the AUTO/GPIB key to return to normal display mode.

Setting the Model 3322/3330 address and delimiter

1. Press the SET UP key to enter the auxiliary setup mode.
2. Press the PREV key, and note the GPIB address and delimiter settings on the **B** DISPLAY section.
3. If the GPIB parameter not presently set to 2.0, use the numeric keys to set the parameter to that value.
4. Press the ENTER/EXIT key twice to return to normal display.

If you are calibrating a Model 3330, set the primary address of the digital multimeter to 22. See the multimeter documentation for details.

6.1.4 Calibration adjust terminal

TP101, which is accessible through a hole in the rear panel, must be connected to the front panel G terminal during calibration. To ground TP101, complete the following steps:

1. Remove the rubber plug that covers the rear panel access hole.
2. Connect a clip lead or probe between TP101 and the front panel G terminal as shown in Figure 2.

6.2 Calibration program

6.2.1 Overview

The supplied calibration program is used to control the LCZ meter to be calibrated from the PC over the GPIB interface. The values of a set of resistance standards are measured, and the deviation between the measured values and the correct values stored in the reference data file are calculated. Corrected data are then written to RAM located in the LCZ meter, and the instrument uses these corrected values during normal measurements.

Model 3330 calibration includes an additional procedure, which calibrates voltage display and signal level using a digital multimeter.

6.2.2 Running the calibration program

To run the calibration program, change to the directory in which the calibration program is located, then type the following:

```
CAL <Enter>
```

6.2.3 Main menu

When the calibration program is run, the following main menu will appear on the computer screen:

Main Menu Screen

3321/3322/3330 Calibration System Ver. 1.00		
Calibration Process		
Save Environment Data		
Manipulate Calibration Data		
QUIT		
ENVIRONMENT DATA	Key wait sound (← →)	OFF
	Calibration Data PATH	c:\cal\
	Reference Data FILENAME	refdata
	GPIB Board present (← →)	NI-PC11A
	MULTIMETER type (← →)	hp3458a
<ARROW - Change Field>		<CR - Select Field/Edit>

All menus in the calibration program are regular popup menus. Use the four arrow keys to select the current field, which will be highlighted. Press the <Enter> key to select or edit a given field. Note that the default field upon program entry is the "Calibration Process" field.

If an invalid key is pressed (for example, pressing left or right arrow while the "Calibration Process" field is selected), the computer will beep. Pressing <Enter> for the PATH and FILENAME fields in the ENVIRONMENT DATA section will allow you to edit those fields as appropriate. Simply type in the desired path or filename, then press the <Enter> key.

6.2.4 Main menu selections

Briefly, the main menu selections perform the following operations.

Calibration Process

The "Calibration Process" menu selection begins the actual calibration procedure. Refer to paragraph 6.3 for complete details on performing the calibration process procedure.

Save Environment Data

This menu selection allows you to save environment data variables, which can be changed by selecting the desired field with the arrows keys and then pressing <Enter>. Program environment data variables include:

- Key wait sound: The sound generated while the computer is waiting for data during calibration.
- Calibration Data PATH: The path that describes the location of the reference data file. Recall that the reference data file contains the actual values of the calibration standards.

- Reference Data FILENAME: The name of the file that contains the resistance standards values. The default name for this file is "REFDATA".
- GPIB Board present: The field shows the type of GPIB board installed in the computer. The two supported GPIB interfaces are the Keithley KM-488-ROM and the National Instruments PC-IIA boards.
- MULTIMETER type: This field identifies the type of digital multimeter to be used for calibration (a multimeter is used only when calibrating the Model 3330). The two types of meters supported are the Hewlett-Packard Model 3458A and the Fluke Model 8840A/42A.

Environment variables are stored in the "SAVESET" file located in the current directory.

Manipulate Calibration Data

This menu selection allows you to read and write the LCZ meter calibration table and display file contents on the computer screen. Refer to paragraph 6.4 for complete information on data manipulation.

QUIT

Selecting "QUIT" exits the calibration program and returns you to the DOS prompt.

6.3 Calibration process

1. To begin calibration, select "Calibration Process" on the main menu, then press <Enter>. The computer will display the following screen to remind you of the required 30-minute warm-up period:

Calibration Process Screen [1]

3321/3322/3330 Calibration System Ver. 1.00
<p>***** CHECK *****</p> <p>Check that the environment temp. is $23 \pm 1^{\circ}\text{C}$.</p> <p>Power-On all LCZ meters to be calibrated</p> <p>For 3330 calibration, Power-On the 'hp3458a' multimeter also.</p> <p>Press any key to continue ([ESC] << ABORT >>)</p>

2. If you wish to continue calibration, press any key except <Esc>. To return to the main menu, press <Esc>.
3. Next, the following screen will be displayed:

Calibration Process Screen [2]

3321/3322/3330 Calibration System Ver. 1.00	
CALIBRATE	
QUIT	
How many LCZ Meters? 3	
Machine 1 Serial No. 00000	
Machine 2 Serial No. 00000	
Machine 3 Serial No. 00000	
<ARROW - Change Field>	<CR - Select/Edit>

The default number of LCZ meters is 1, and you can calibrate up to five units in a single calibration run. Changing the number of LCZ meters will affect the number of serial number fields that are displayed.

4. After selecting the number of units, select "CALIBRATE" to continue calibration. If you wish to return to the main menu at this point, select "QUIT" instead.
5. The next screen will remind you that all LCZ meters should be allowed to warm up for at least 30 minutes in the calibration environment before calibration. The screen first prompts you as to whether or not the LCZ meters have been warming up for at least 30 minutes. A negative response will cause the program to go to a 30-minute wait state (the program uses the DOS time function to time the length of the waiting period).

Calibration Process Screen [3]

3321/3322/3330 Calibration System Ver. 1.00	
Have machines been running for at least 30 minutes (Y/N)	
Leave machine in powered on state until 10:59:54 before calibrating. ([ESC] << ABORT >>)	
Current Time = 10:30:04 Remaining = 00:29:50	

Note that the current time and remaining time values will be continuously updated while waiting. After 30 minutes have elapsed, the next screen will be displayed.

6. The next screen will remind you about GPIB connections, the primary address, and shorting the calibration adjust terminal:

Calibration Process Screen [4]

3321/3322/3330 Calibration System Ver. 1.00
Calibration unit No. 1 Serial No. 123456
CAUTION!!
Rear panel : Connect the adjust cable between ADJ and GND.
Front panel : Set GPIB address and delimiter [2.0]
Make sure that GPIB cable is connected between the unit and PC
Press any key to continue..... ([ESC] << ABORT >>)

7. Make sure that calibration adjust terminal is shorted and that the instrument is properly connected to the GPIB. Also make sure the primary address/delimiter setting is 2.0.
8. If you are calibrating a Model 3330, the next screen will guide you through signal level calibration and voltage monitor calibration of the Model 3330 LCZ Meter. Before continuing with this step, you should make sure that the digital multimeter is turned on, and its primary address is set to 22. Also make sure that the multimeter is connected to the Model 3330, as shown in Figure 1.

Calibration Process Screen [4a] (Model 3330 Only)

3321/3322/3330 Calibration System Ver. 1.00
Calibrate the Frequency Response of the 3330's voltage monitor.
Calibrate the signal level of the 3330. Calibrating the signal level . . .
Connect 3330 and 'hp3458a' multimeter using SPECIAL JIG.
Press any key to continue..... ([ESC] << ABORT >>)

The program will allow you to abort the process at various stages. Errors are reported at the bottom of the screen to prompt you regarding signal cable, GPIB address, etc.

9. Press any key except <Esc> to continue with calibration. During calibration, the computer will prompt you to connect standards using the following screen:

```
3321/3322/3330 Calibration System Ver. 1.00

Model:3321 Unit No. :3 Serial No.: 123456 Sample Set: 2/2

Attach 'OPEN' STANDARD
***** DONE !!

Attach 'SHORT' STANDARD
***** DONE !!

Attach '100Ω' STANDARD
***** DONE !!

Attach '1KΩ' STANDARD
***** DONE !!

Attach '10KΩ' STANDARD
***** DONE !!

Attach '100KΩ' STANDARD
***** DONE !!

Press any key to continue..... ([ESC] << ABORT >>)
```

10. During this part of the calibration process, you will be prompted to connect each of the following standards to the LCZ meter twice:

OPEN	1kΩ
SHORT	10kΩ
100Ω	100kΩ

These standards should be connected to the LCZ meter, as shown in Figure 3.

NOTE

Be sure to connect the H and L terminals of each standard to the corresponding HI and LO terminals on the LCZ meter.

Do not handle the standards excessively, or the resulting increase in temperature may result in inaccurate calibration.

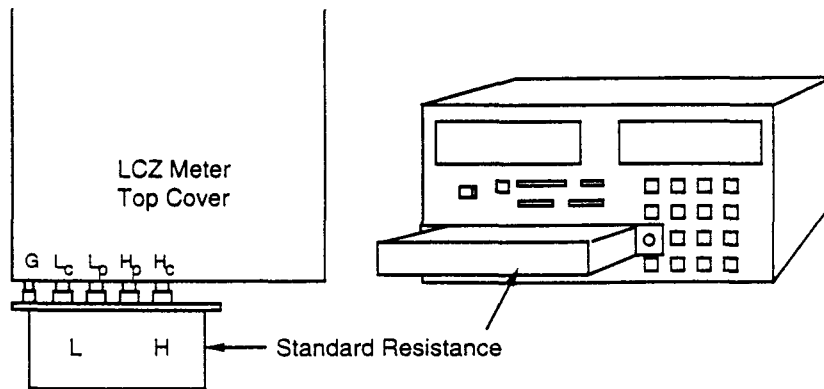

Figure 3. Calibration standards connections

11. After connecting each standard, press any key except <Esc> to continue with calibration. You can press <Esc> to abort the calibration process and return to the main menu.
12. If you are calibrating more than one unit, the process will be repeated for each unit.
13. After calibrating the unit(s), the calibration data file is created and written to the computer disk in the current directory. The filename for this file is derived from the DOS date (month/day/year) and time (hour/minutes/seconds) when calibration is performed.

Example: 5/21/92 10:45:03

Filename: "05219210.450"

Values written to the file are in ASCII representation of double-precision floating-point numbers. The instrument model number and serial number will also be written to the file.

14. When all units have been calibrated, the following message screen will be displayed:

Calibration Process Screen [6]

3321/3322/3330 Calibration System Ver. 1.00
<p>Check sum is being written ...</p> <p>Finished calibration for 3 unit(s).</p> <p>Press any key to continue.....</p>

15. Press any key to return to the main menu.

NOTE

Calibration is now complete. However, new calibration constants do not go into effect until power is cycled. See the following paragraph to determine if calibration was successful.

6.3.1 Post calibration

After calibration has been completed, remove the jumper clip connected between TP101 and G, and install the rubber plug in the access hole. Turn off the power for three seconds, then turn the unit back on, and verify that the instrument goes through its power-up self-calibration cycle without errors. If the errors "EEEE" and "2222" appear on the **A** and **B** DISPLAY sections, repeat the calibration procedure. If the error persists, the battery that backs up calibration constants RAM may require replacement, or the unit may require repair. (See the Model 3321/3322 Service Manual or the Model 3330 Service Manual for information on battery replacement and repair.)

To verify calibration accuracy, perform the verification procedures described in Section 1 of the respective service manual.

6.4 Manipulate Calibration Data

Selecting "Manipulate Calibration Data" from the main menu will display the following screen and allow you to perform the operations described below.

Manipulate Calibration Data Screen

3321/3322/3330 Calibration System Ver. 1.00	
Directory Listing Write Machine Table Read Machine Table Type File QUIT	
SPECIFICATION >> _	
<ARROW - Change Field>	<CR - Select/Edit>

Directory Listing

This selection will allow you to display a listing of files in a manner similar to the DOS "DIR" command. When selected, the program will display the following prompt for the directory to be displayed:

SPECIFICATION >> _

Enter the desired path, then press <Enter>. The default path is the current directory, and the output is paginated.

Write Machine Table

This menu selection writes calibration data from a given computer data file to Model 3321/3322/3330 RAM. When this menu item is selected, the computer will prompt you for the name of the calibration data file as follows:

WRITE Machine Table FROM file name >> _

Type in the name of the file to be loaded, then press <Enter>. A list of data sets with serial numbers and model numbers will be displayed on the screen. Enter the number corresponding to the data set to be written to the Model 3321/3322/3330, then press <Enter>.

NOTE

The Model 3321/3322/3330 must be in the calibration adjust mode (TP101 connected to G) in order to write calibration data to the instrument. Also be sure that the instrument is connected to the GPIB interface of the computer.

Read Machine Table

This menu selection reads the calibration table from the LCZ meter and stores data in a designated disk file. When this item is selected, the program will prompt you for the filename as follows:

READ Machine Table TO file name >> _

Type in the desired filename, then press <Enter>. The unit will then prompt for the serial number and model number:

Serial NO. & Model Type >> _

Type in the pertinent information, then press <Enter>. The calibration table will be read from the instrument, and the data will be stored in the designated computer data file.

Type File

This menu selection allows you to display the contents of a designated ASCII file on the computer screen. When this item is selected, the instrument will prompt you for the name of the file:

FILESPEC >> _

Type in the name of the file, then press <Enter>. The display will be paginated if necessary.

QUIT

Selecting QUIT will return you to the main menu screen of the calibration program.